

## Qontronic specifications

Qontronic is a hosting board for TiniQ<sup>1</sup> and works as a flexible programmable module for control and communication. It comprises a main PCB that holds the TiniQ and all the I/O's and communication connections, and, optionally, a second PCB with a 20x4 LCD display, a 6-keys keyboard, some leds and a beeper. This second PCB is connected to the main PCB via SPI.

Qontronic is enclosed in a modular case according to DIN 43880 standard that can be fastened to DIN (EN 60715) rail. It is shown in next figure. The terminal blocks are assembled on both sides of the case while the display and keyboard are placed in the front panel (in the versions with the second PCB included). If second PCB is not present a blind cover will be as front panel as shown in the figure.



The dimensions of the Qontronic module are shown in next figure.

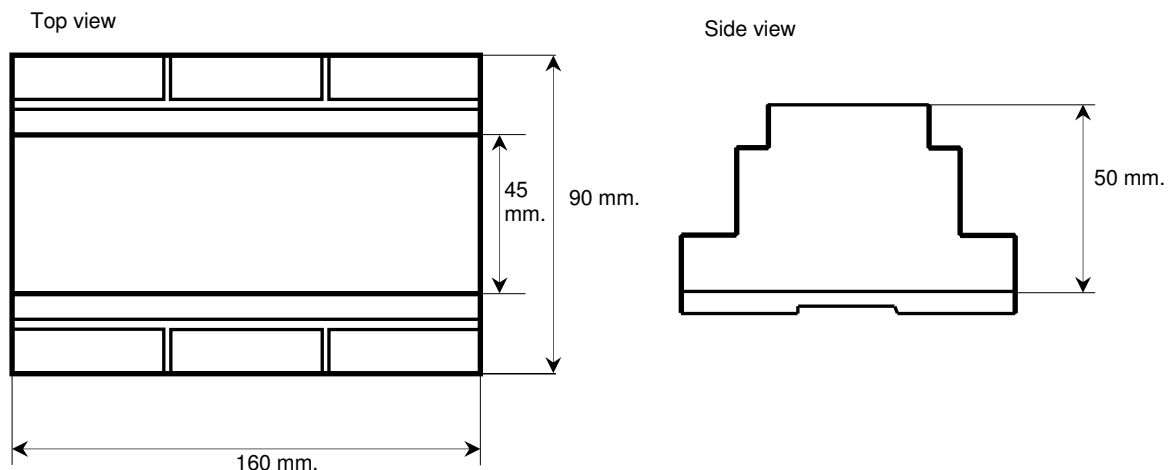

<sup>1</sup> TiniQ is the microcontroller stick developed by Qontinum-Plus S.L. based on Maxim/Dallas DS400 chipset. There are two versions: TiniQ/10 (which includes the DS80C410 microprocessor) and TiniQ/11 (which includes the DS80C411 microprocessor).

Next figure shows a top view diagram, where all the possible interfaces are presented:

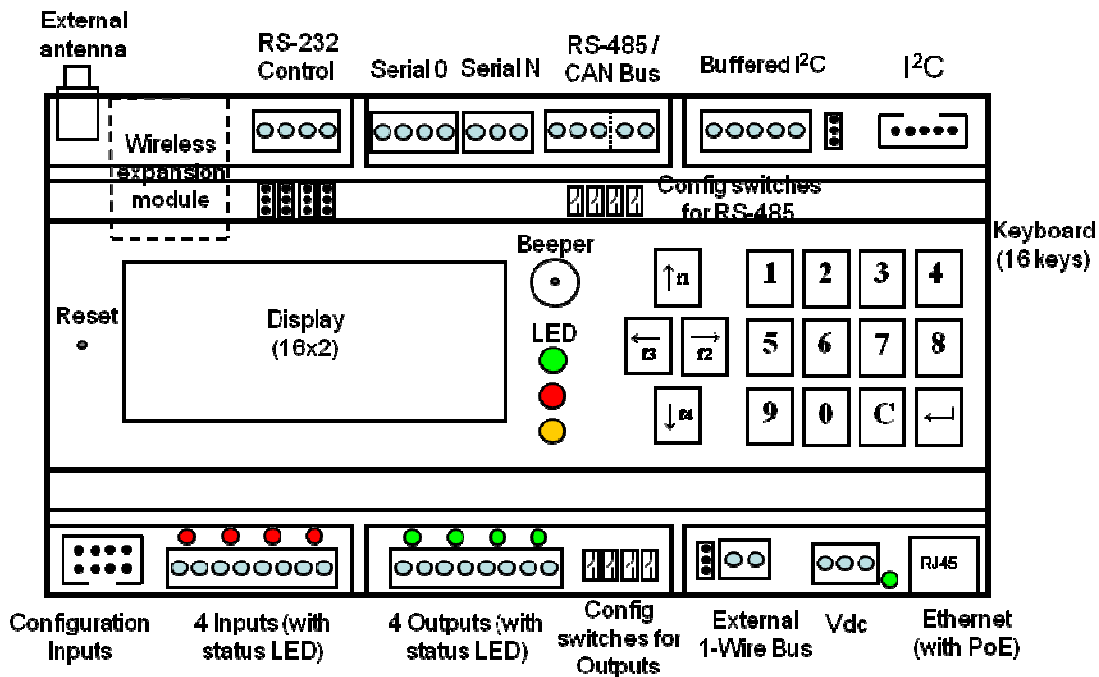

Qontronic provides:

- 4 digital (opto-coupled) differentials Inputs that can generate interruptions. Each input has a status red LED.
- 4 digital (opto-coupled) Outputs with solid-state relays. Each output has a status green LED.
- Optional WPAN expansion module<sup>2</sup> for 6LoWPAN, ZigBee® or other compatible with IEEE 802.15.4.
- 2 Serial ports RS-232, Serial 0 and Serial N<sup>2</sup>.
- Connector with RS-232 serial control signals (DTS, DTR, CTS, etc). It is configurable for any Serial port.
- Opto-isolated RS-422/485<sup>2</sup> or CAN Bus depending on the model (the use of CAN Bus requires a TiniQ/10).
- Ethernet via RJ45 connector enabled for PoE (*Power over Ethernet*), according to IEEE 802.3af.
- Connector for external power supply (12-45Vdc) when not using PoE.
- iButton Clip connected to the internal 1-Wire Bus of TiniQ.
- 1-Wire Bus interface connected to the external 1-Wire Bus. It is internally shared with the Serial 1 port of TiniQ, so both can not be used at the same time.
- Connectors for I<sup>2</sup>C Bus and buffered I<sup>2</sup>C Bus.
- Dip-Switches for Outputs settings.
- Pins connector to be used as general configuration inputs via jumper or other external device (push-button, tamper switch, etc.).
- 16x2 LCD display (in the optional PCB).
- 16-keys keyboard (in the optional PCB).
- 3 general purpose LED (in the optional PCB).
- Beeper (in the optional PCB).

<sup>2</sup> It can be connected to Serial 1 or Serial 4 of TiniQ (selectable via internal register).